

Dairy Products 1

Cheesemaking



A webinar presented by:

Dr Andy Bowles

Attendee Notes

 **Food Law**

Dairy Products 1
Cheesemaking



abc Food Law

1

This webinar will consider

- Introduction
- Typical process
- Types of cheese
- Technology
- Common hazards and controls

abc Food Law

2

Cheesemaking

- Introduction
- Typical process
- Types of cheese
- Technology
- Common hazards and controls

abc Food Law

3

Cheese - Codex definition

DESCRIPTION

Cheese is the ripened or unripened soft, semi-hard, hard, or extra-hard product, which may be coated, and in which the whey protein/casein ratio does not exceed that of milk, obtained by:

- (a) coagulating wholly or partly the protein of milk, skimmed milk, partly skimmed milk, cream, whey cream or buttermilk, or any combination of these materials, through the action of rennet or other suitable coagulating agents, and by partially draining the whey resulting from the coagulation, while respecting the principle that cheese making results in a concentration of milk protein (in particular, the casein portion), and that consequently, the protein content of the cheese will be distinctly higher than the protein level of the blend of the above milk materials from which the cheese was made; and/or
- (b) processing techniques involving coagulation of the protein of milk and/or products obtained from milk which give an end-product with similar physical, chemical and organoleptic characteristics as the product defined under (a).

Ripened cheese is cheese which is not ready for consumption shortly after manufacture but which must be held for such time, at such temperature, and under such other conditions as will result in the necessary biochemical and physical changes characterizing the cheese in question.

Mould ripened cheese is a ripened cheese in which the ripening has been accomplished primarily by the development of characteristic mould growth throughout the interior and/or on the surface of the cheese.



Unripened cheese including fresh cheese is cheese which is ready for consumption shortly after manufacture.



4

Cheese

- Coagulation of milk protein and concentration of milk fat
 - Different methods of coagulation
 - Rennet
 - Acid
 - Heat



5

Cheese

- Cheese may be made from
 - Raw milk
 - Thermised milk
 - Pasteurised milk
- Note: Heat treatment of milk is not always a CCP



6

Cheesemaking

- Introduction
- Typical process
- Types of cheese
- Technology
- Common hazards and controls



7

Cheese

- Essential steps:
 - Coagulation –
 - gel formed by action of enzymes/acid
 - Removal of whey leaving curd
 - Syneresis
 - Acid production in curd
 - Salting
 - Fusion of curd grains
 - Ripening



8

Cheese

- Manufacture process may include:
 - Ageing the Milk
 - Setting the Vat
 - Cutting The Curd
 - Cooking
 - Draining
 - Washing
 - Curd Handling
 - Pressing
 - Salting



9

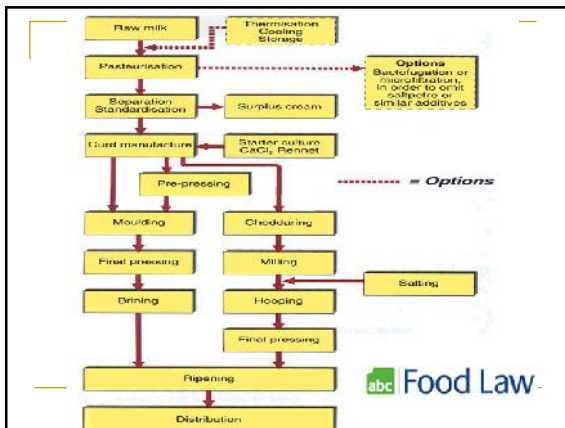

10

The screenshot shows the 'Codex Alimentarius standards' website. The header includes the logo and 'INTERNATIONAL FOOD STANDARDS'. A search bar contains the word 'cheese'. Below the search bar, there is a table of standards. The table has columns for 'Reference', 'Title', 'Committee', 'Last modified', and a series of status icons (checkmarks and X's).

Reference	Title	Committee	Last modified	EN	ES	FR	AR	CH	RU
CD 208 (1999)	Group Standard for Cheese in Brine	CCMWP	2016	✓	✓	✓	✓	✓	✓
CD 221 (2001)	Group Standard for Crumbly Cheese including Fresh Cheese	CCMWP	2016	✓	✓	✓	✓	✓	✓
CD 272 (1988)	Standard for Cheddar Cheese	CCMWP	2016	✓	✓	✓	✓	✓	✓
CD 292 (1978)	Standard for Cream Cheese	CCMWP	2016	✓	✓	✓	✓	✓	✓
CD 276 (1978)	Standard for Soft Spreadable Cheese	CCMWP	2016	✓	✓	✓	✓	✓	✓
CD 280 (1978)	General Standard for Cheese	CCMWP	2016	✓	✓	✓	✓	✓	✓
CD 284 (1971)	Standard for Whey Cheese	CCMWP	2016	✓	✓	✓	✓	✓	✓

11

The screenshot shows the 'Protected names: EU' page on the European Commission website. It features the EU flag and the text 'EUROPEAN COMMISSION eAmbrosia - the EU geographical indications register'. Below this, there is a search bar and a table of records. The table has columns for 'Product Name', 'Country', 'Type', 'File number', 'Name', 'Product Category', 'Status', and 'Date'.

Product Name	Country	Type	File number	Name	Product Category	Status	Date
Wine de Macon	France	Protected Designation of Origin (PDO)	PGO-FR-115-AR01	Wine de Macon	Class 1.3, Cheeses	Published	27/02/2000
Canal / Fournes de Canal	France	Protected Designation of Origin (PDO)	PGO-FR-013-AR02	Canal / Fournes de Canal	Class 1.3, Cheeses	Published	11/03/2000
Brevasse de Rivet	France	Protected Designation of Origin (PDO)	PGO-FR-024	Brevasse de Rivet	Class 1.3, Cheeses	Published	27/01/2002
Capriotto di Salsola	Italy	Protected Geographical Indication (PGI)	PGI-IT-00381	Capriotto di Salsola	Class 1.3, Cheeses	Published	06/01/2003
Tonnes des Pyrénées	France	Protected Geographical Indication (PGI)	PGI-FR-0178-AR01	Tonnes des Pyrénées	Class 1.3, Cheeses	Published	23/12/2016

<https://ec.europa.eu/info/food-farming-fisheries/food-safety-and-quality/certification/quality-labels/geographical-indications-register/#>

12

EU Protected names

The screenshot shows a search result for 'Xakloupi / Helim / Haloumi / Hellim'. A modal window displays the following details:

- Product Type: Food
- File number: FPO-01-0249
- Type: Protected designation of origin (PDO)
- Country: Cyprus
- Status: Published
- Product Category: Case I.3. Cheeses
- Application date: 11/07/2014
- Date of Publication: 28/07/2015
- Publication: [Official Journal C136 28.07.2015](#)

abc Food Law

13

UK Protected Names

- <https://www.gov.uk/government/collections/protected-food-name-scheme-uk-registered-products#cheeses>

Cheeses

- Protected food name: [Beacon Fell traditional Lancashire cheese \(PDO\)](#)
14 January 2014 | Substance
- Protected food name: [Banchester cheese \(PDO\)](#)
7 August 2007 | Substance
- Protected food name: [Buxton Blue cheese](#)
7 August 2007 | Substance
- Protected food name: [Dorset Blue cheese \(PGI\)](#)
7 August 2007 | Substance
- Protected food name: [Dovedale cheese \(PDO\)](#)

abc Food Law

14

UK Protected names

Protected food name: Single Gloucester (PDO)

The specification for Single Gloucester, a protected food name product.

Published 7 August 2007
From: [Department for Environment, Food & Rural Affairs](#)

Documents

- [Product specification: Single Gloucester \(PDO\)](#)
PDF 73.9kB, 4 pages
This file may not be suitable for users of assistive technology. [See our accessibility forum.](#)

Related content

- [Protected food name: Baccaratine pers \(PGI\)](#)
- [Protected food name: Emmentaler alps \(PGI\)](#)
- [Protected food name: Somerset cheese \(PDO\)](#)

abc Food Law

15

Single Gloucester

- Method of production:
 - Pasteurised or unpasteurised milk put into vat
 - Starter culture added and temperature raised to 30 - 32C
 - 2• 3/4 hours after addition of starter, 1ml of rennet (or non-animal coagulants) per 3.5-5 litres of milk is added
 - Curd sets in from 25 minutes – 1 hour
 - Curd cut for 10-20 minutes
 - Curds and whey scalded for 20-30 minutes, up to 32 - 35C
 - Whey is run off and drained
 - Curd milled and salted (1.4 – 5 gms salt per initial litre of milk, depending on moisture of curd)
 - Mould and press
 - Cheese turned in moulds same evening or next day. Cheese out of press next day or up to 5 days later
 - Cheese ready for consumption at about 2 months



16

Cheesemaking

- Introduction
- Typical process
- Types of cheese
- Technology
- Common hazards and controls



17

Types of cheese

- Cheese can be placed into groups;
 - Acid-coagulated Fresh Cheese
 - Rennet-coagulated Fresh Cheese
 - Heat-Acid Precipitated Cheese
 - Soft-Ripened Cheese
 - Semi-hard Washed Cheese
 - Hard Cheese: Low temperature
 - Hard Cheese: High Temperature



18

Acid-coagulated Fresh Cheese

- 'Fresh cheese'
 - produced by acid coagulation at 30 - 32°C with little or no added rennet.
 - Coagulation: by acidification to pH 4.6 - 4.8, with little or no coagulating enzyme.
 - Acidity produced by lactic acid bacteria
 - After cutting at pH 4.6-4.8, curd is cooked to 52 C
 - Varieties: Cottage cheese and Quark



19

Rennet-coagulated Fresh Cheese

- Varieties: Queso Blanco, Queso Fresco, Italian fresh cheese, Halloumi
- Coagulation is entirely by rennet.
 - pH is normally in the range of 6.5-6.7.



20

Heat-Acid Precipitated Cheese

- **Varieties:** Ricotta and Paneer
- **Coagulation:** direct acidification of heated milk.
 - High heat treatment of milk causes denaturation of the whey proteins.
 - Subsequent acidification of the hot milk coagulates both casein and whey proteins,
 - most of the milk protein is recovered in the cheese.
- Final pH is normally in the range of 5.3 - 5.8.



21

Soft-Ripened Cheese

- **Varieties:** Fetta, Camembert, Brie
- **Coagulation:** rennet with important differences to cooked and pressed varieties:
 - Lactic acid bacteria inoculum is large
 - Ripening period before renneting is extended.
 - Cutting is delayed
 - encourages acidification and demineralization before cutting.
 - Cutting with large knives or paddles
 - to minimize moisture and fines losses.



22

Semi-hard Washed Cheese

- **Varieties:** Gouda, Edam.
- Part or all of the whey is removed
 - replaced with water to leach lactose from the curd.
- limits the amount of lactose
 - to a level which permits sufficient lactic acid development to produce a minimum pH of 5.0 - 5.2,
 - but not enough to ferment



23

Hard Cheese: Low temperature

- **Varieties:** Cheddar
- **pH Control:** Acid development is mainly controlled by the amount of syneresis.
 - pH of 5.0 - 5.2 within 1 - 3 days after manufacture.
 - Lactose content is substantially reduced by fermentation with associated moisture loss during cheddaring and vat salting.



24

- Cheddar Cheese (Farmhouse method)
- Cheddaring : curd cut into large strips
- Milling : Curd cut into small strips

abc Food Law

25

Hard Cheese: High Temperature

- **Varieties:** Parmesan
- **pH Control:** Little acid development before draining.
- **Moisture Control:** Rapid syneresis induced by high renneting temperature and high cooking temperature.
- **Curing:** 1 - 36 months.

abc Food Law

26

Cheesemaking

- Introduction
- Typical process
- Types of cheese
- Technology
- Common hazards and controls

27

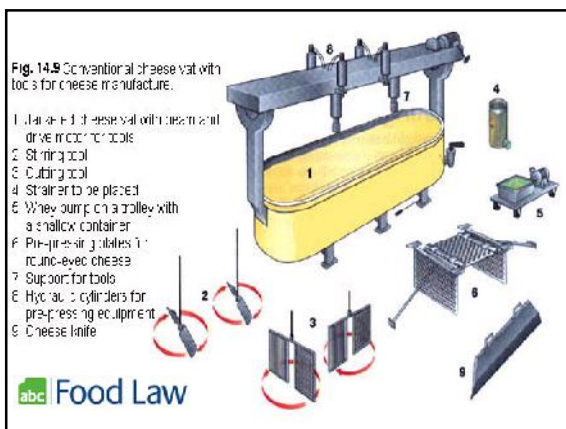

28



29



30



31



32



33

This webinar will consider

- Introduction
- Typical process
- Types of cheese
- Technology
- Common hazards and controls

34

Specialist cheesemakers association
<http://www.specialistcheesemakers.co.uk/>

Navigation menu items: About SCA, Primary Authority & Assured Code, SCA Members, Technical, Events, News & Awards, For Sale/Wanted.

Central image: Welcome to the SCA website. To access full information, SCA members must [activate](#) their account and then [Log in here](#), SCA members.

35

HACCP

- Prerequisites
 - Layout/design
 - Training etc
- Proformas
 - Artisan
 - Processed cheese

Logos: European Guide for Good Hygiene Practices in the production of artisanal cheese and dairy products; Farmhouse and Artisan Cheese & Dairy Producers European Network; abc Food Law.

36

Allergens

- Non-declared
 - Added ingredients
 - Dried fruits: Sulphur dioxide
 - Lysozyme - Egg
 - Cross contamination
 - Herbs and spices
 - Sesame
 - Celery
 - Mustard





40

Summary

- Introduction
- Typical process
- Types of cheese
- Technology
- Common hazards and controls



41

Dr Andy Bowles

andy.bowles@abcfoodlaw.co.uk

www.abcfoodlaw.co.uk
[@abcfoodlaw](https://twitter.com/abcfoodlaw)
01603 319863

42

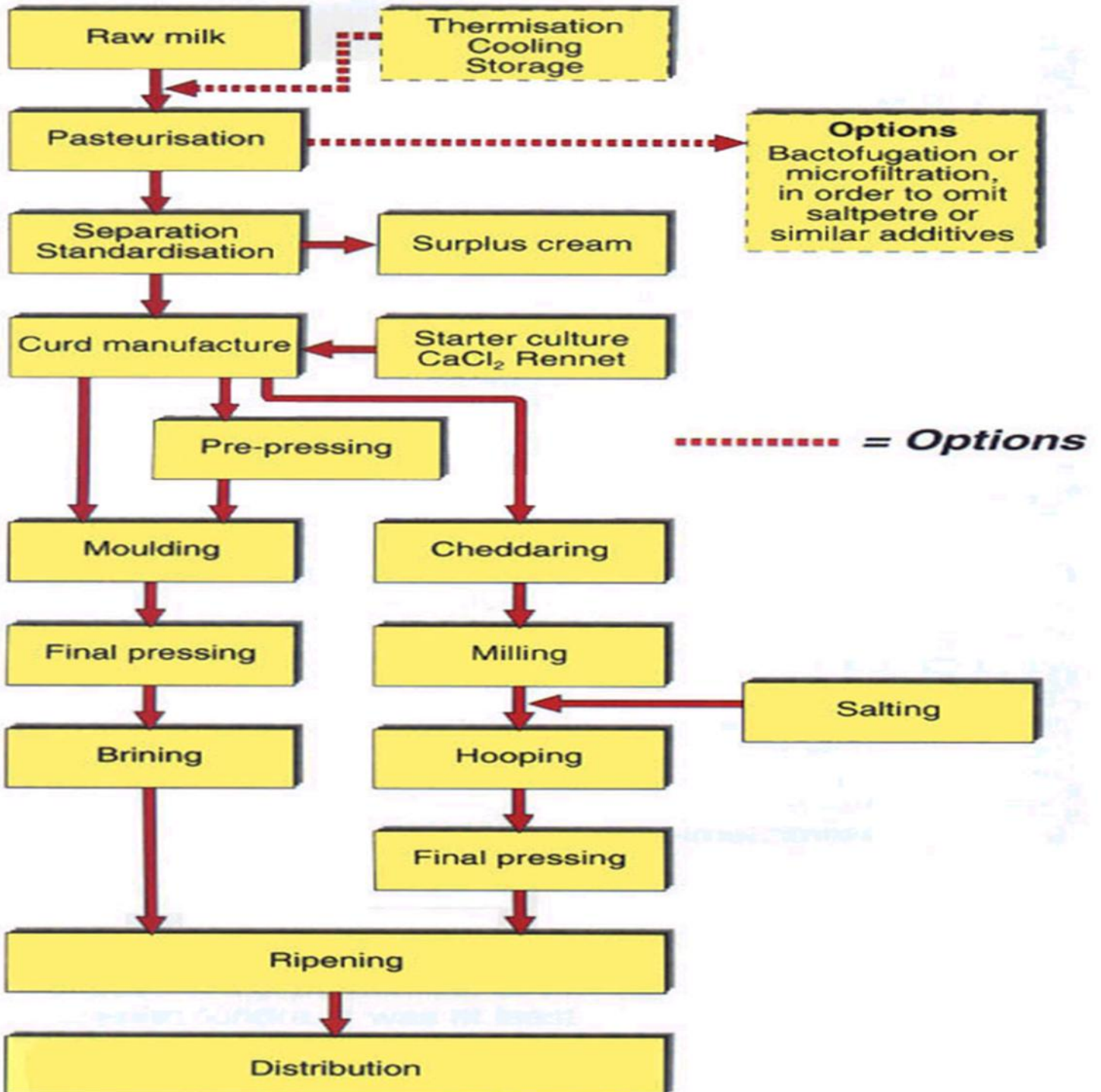

Codex Alimentarius standards

العربية 中文 English Français Pycckий Español

CODEX ALIMENTARIUS

INTERNATIONAL FOOD STANDARDS

support **2020** World Food Safety Day

Food and Agriculture Organization of the United Nations

World Health Organization

Home About Codex Codex Texts Themes Committees Meetings Resources Publications News And Events Login

codexalimentarius > Codex Texts > Standards

Standards

Click on any column to order the list of standards. Use the yellow arrow to order the data ascending or descending.

Type any criteria in the search box to filter the data (e.g. a year, a committee code or a keyword). Download a standard by clicking on the green symbol in the available languages indicated.

cheese

Reference	Title	Committee	Last modified	EN	FR	ES	AR	ZH	RU
CXS 208-1999	Group Standard for Cheeses in Brine	CCMMP	2018	✓	✓	✓	✓	✓	✓
CXS 221-2001	Group Standard for Unripened Cheese including Fresh Cheese	CCMMP	2018	✓	✓	✓	✓	✓	✓
CXS 273-1968	Standard for Cottage Cheese	CCMMP	2018	✓	✓	✓	✓	✓	✓
CXS 275-1973	Standard for Cream Cheese	CCMMP	2018	✓	✓	✓	✓	✓	✓
CXS 278-1978	Standard for Extra Hard Grating Cheese	CCMMP	2018	✓	✓	✓	✓	✓	✓
CXS 283-1978	General Standard for Cheese	CCMMP	2018	✓	✓	✓	✓	✓	✓
CXS 284-1971	Standard for Whey Cheeses	CCMMP	2018	✓	✓	✓	✓	✓	✓

Showing 1 to 7 of 7 entries (filtered from 224 total entries)

Protected names: EU

Search on EUROPA | Contact | Cookies | Legal notice | Privacy statement | English (en)

 EUROPEAN COMMISSION
eAmbrosia – the EU geographical indications register

Home > Food, Farming, Fisheries > Food safety and quality > Certification > Quality labels > Geographical indications register

Search Wine Register Food Register Spirit drinks 11 Records

Product Type	Country	Type	File number	Name	Product Category	Status	Date	
Food	France	Protected Designation of Origin (PDO)	PDO-FR-0110-AM01	Brie de Meaux	Class 1.3. Cheeses	Published	27/02/2020	
Food	France	Protected Designation of Origin (PDO)	PDO-FR-0113-AM02	Cantal / Fourme de Cantal	Class 1.3. Cheeses	Published	11/02/2020	
Food	France	Protected Designation of Origin (PDO)	PDO-FR-02424	Brousse du Rove	Class 1.3. Cheeses	Published	27/01/2020	
Food	Romania	Protected Geographical Indication (PGI)	PGI-RO-02361	Caşcaval de Săveni	Class 1.3. Cheeses	Published	16/01/2020	
Food	France	Protected Geographical Indication (PGI)	PGI-FR-0176-AM01	Tomme des Pyrénées	Class 1.3. Cheeses	Published	23/12/2019	

<https://ec.europa.eu/info/food-farming-fisheries/food-safety-and-quality/certification/quality-labels/geographical-indications-register/#>

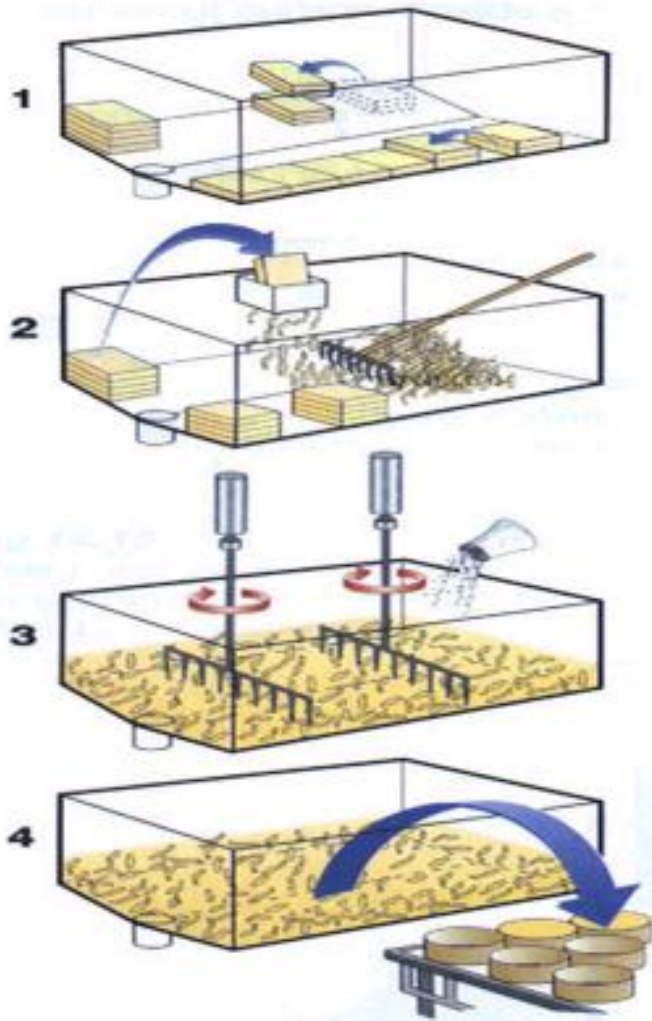

- Cheddar Cheese (Farmhouse method)
- Cheddaring : curd cut into large strips
- Milling : Curd cut into small strips

Fig. 14.9 Conventional cheese vat with tools for cheese manufacture.

- 1 Jacketed cheese vat with beam and drive motor for tools
- 2 Stirring tool
- 3 Cutting tool
- 4 Strainer to be placed
- 5 Whey pump on a trolley with a shallow container
- 6 Pre-pressing plates for round-eyed cheese
- 7 Support for tools
- 8 Hydraulic cylinders for pre-pressing equipment
- 9 Cheese knife

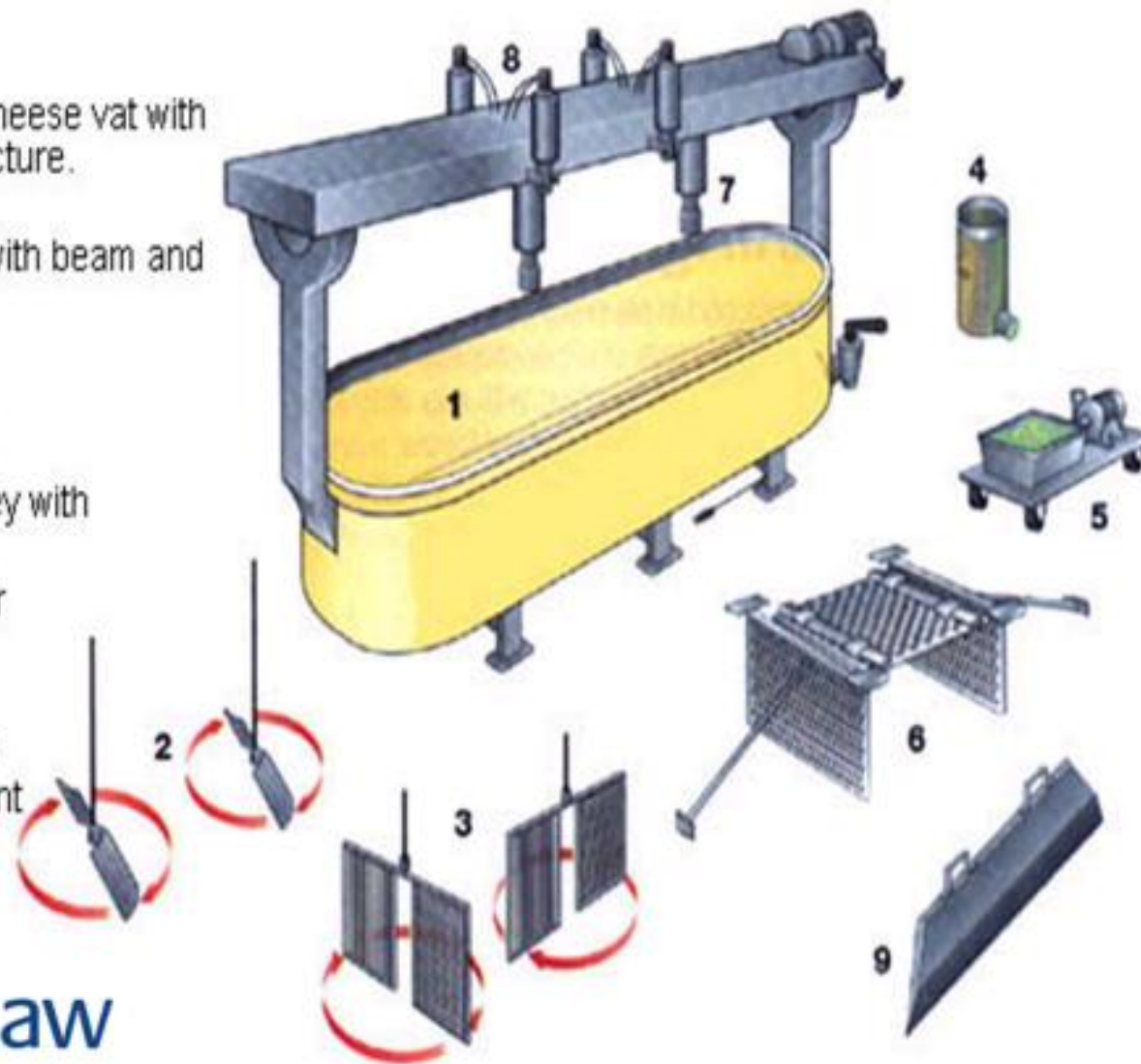

Food safety criteria

Organism	Food	Criterion	n	c	m	M	Definition
<i>Listeria monocytogenes</i>	Ready to Eat (RTE) foods able to support the growth of <i>Listeria</i>	1.2	5	0	Absent in 25g		In five samples, none may exceed "absent in 25g" before the food leaves the immediate control of the producer, when the FBO is not able to demonstrate, to the satisfaction of the competent authority, that the product will not exceed 100cfu/g throughout the shelf-life.
		1.2	5	0	100cfu/g		In five samples, none may exceed 100cfu/g within the shelf life of a product placed on the market, when the FBO is able to demonstrate, to the satisfaction of the competent authority, that the product will not exceed this limit throughout the shelf-life.
	RTE foods unable to support the growth of <i>Listeria</i> This category includes products with: <ul style="list-style-type: none"> • pH ≤4.40 or; • a_w ≤0.92 or; • pH ≤5.00 and a_w ≤0.94 or; • shelf life <5 days. • Other products subject to scientific justification. 	1.3	5	0	100cfu/g		In five samples, none may exceed 100cfu/g within the shelf life of a product placed on the market.
<i>Salmonella</i>	Cheese, butter or cream made from raw/unpasteurised milk (Unless the producer can satisfy the competent authority that there is no <i>Salmonella</i> risk due to ripening time and a _w .)	1.11	5	0	Absent in 25g		In five samples, all must be "absent in 25g" within the shelf life of a product placed on the market.
	Ice Cream (except where the manufacturing process or the composition will eliminate the risk).	1.13	5	0	Absent in 25g		In five samples, all must be "absent in 25g" within the shelf life of a product placed on the market.
<i>Staphylococcal Enterotoxin</i>	Cheese as referred to in the Process Hygiene Criteria relating to Coagulase Positive Staphylococci (CPS) (2.2.3, 2.2.4 & 2.2.5)	1.21	5	0	Not Detected in 25g		In five samples, all must be "Not Detected in 25g" within the shelf life of a product placed on the market. This criterion applies where levels of CPS exceed 10 ⁵ /g at the point specified in the relevant process hygiene criterion.

Process hygiene criteria

Organism	Food	Criterion	n	c	m	M	Definition	Action in case of unsatisfactory results (see below)
<i>E. coli</i>	Cheeses made from milk or whey which has undergone heat treatment	2.2.2	5	2	100 cfu/g	1000 cfu/g	In five samples, two may exceed 100 cfu/g as long as none exceed 1000 cfu/g, at the time during manufacture when the count is expected to be highest. **	A & B
	Butter and Cream made from Raw Milk (or milk that has undergone a lower heat treatment than pasteurisation.)	2.2.6	5	2	10 cfu/g	100 cfu/g	In five samples, two may exceed 10 cfu/g as long as none exceed 100 cfu/g, at the end of the manufacturing process.	A, B & C
Coagulase Positive Staphylococci Where values >10 ⁵ cfu/g are detected, the cheese batch must be tested for staphylococcal enterotoxins to verify compliance with food safety criterion 1.21.	Cheese made from Raw Milk	2.2.3	5	2	10 000 cfu/g	100 000 cfu/g	In five samples, two may exceed 10 000 cfu/g as long as none exceed 100 000 cfu/g, at the time during manufacture when the count is expected to be highest. **	A, B & C
	Cheese made from Milk which has undergone a lower heat treatment than pasteurisation*	2.2.4	5	2	100 cfu/g	1000 cfu/g	In five samples, two may exceed 100 cfu/g as long as none exceed 1000 cfu/g, at the time during manufacture when the count is expected to be highest. **	A, B & C
	Ripened cheese made from milk or whey that has undergone pasteurisation or stronger heat treatment*						A, B & C	
Unripened soft (Fresh) Cheeses made from milk or whey that has undergone pasteurisation or stronger heat treatment*	2.2.5	5	2	10 cfu/g	100 cfu/g	In five samples, two may exceed 10 cfu/g as long as none exceed 100 cfu/g, at the end of the manufacturing process.	A & C	
Enterobacteriaceae	Pasteurised Milk or other Pasteurised Liquid Dairy Products	2.2.1	5	0	10 cfu/ml		In five samples, none may exceed 10 cfu/ml, at the end of the manufacturing process.	D
	Ice Cream & Frozen Dairy Desserts	2.2.8	5	2	10 cfu/g	100 cfu/g	In five samples, two may exceed 10 cfu/g as long as none exceed 100 cfu/g, at the end of the manufacturing process.	A

Actions to be taken in the event of Unsatisfactory Results as identified in Regulation (EC) 2073/2005

A: Make improvements in production hygiene.

B: Make improvements in selection of raw materials.

C: If values >10⁵ are detected, the cheese batch has to be tested for Staphylococcal Enterotoxins.

D: Check on efficiency of heat-treatment and prevention of recontamination as well as the quality of raw materials.